

# 5300 SERIES

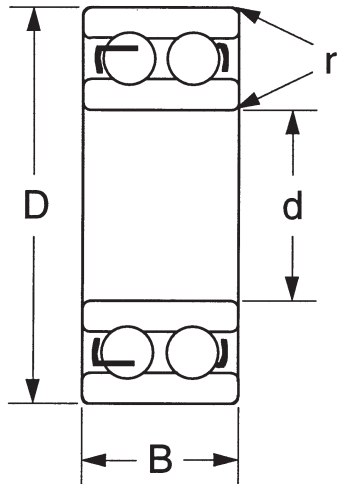

This series is manufactured with the same ID and OD as the 6300 bearings. By utilizing double row construction, the 5300 series is used with heavy radial, combined radial and thrust, or where there are two directional loads. The non-filling slot allows these bearings to be used at high RPM. They are available with shields and seals. Loading groove maximum construction types are manufactured upon request. Consult Peer sales engineer for availability.

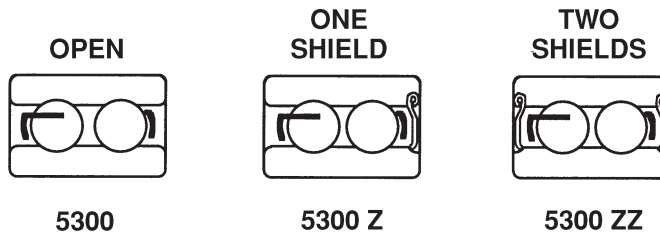

Units: Inches  
Metric

Part Number	Bore d	Tolerance +.0000 to minus	OD D	Tolerance +.0000 to minus	Width B	Tolerance +.0000 to minus	* fillet radii r	Basic Load Ratings		Weight lb Kg	Limiting speed of Open Bearing (rpm)	
								Dynamic Cr	Static Cor		oil	grease
5302	.5906	.0003	1.6535	.0005	.7500	.0047	.039	3,960	2,295	.250	15,000	10,000
	15	.008	42	.011	19.050	.120	1.0	17,600	10,200	.113		
5303	.6693	.0003	1.8504	.0005	.8750	.0047	.039	4,725	2,835	.330	14,000	10,000
	17	.008	47	.011	22.225	.120	1.0	21,000	12,600	.150		
5304	.7874	.0004	2.0472	.0005	.8750	.0047	.039	5,530	3,370	.500	12,000	9,000
	20	.010	52	.011	22.225	.120	1.0	24,600	15,000	.227		
5305	.9843	.0004	2.4409	.0005	1.0000	.0047	.039	7,320	4,650	.750	10,000	8,000
	25	.010	62	.011	25.400	.120	1.0	32,500	20,700	.340		
5306	1.1811	.0004	2.8346	.0005	1.1875	.0047	.039	9,112	6,322	1.100	8,000	6,000
	30	.010	72	.011	30.163	.120	1.0	40,500	28,100	.499		
5307	1.3780	.0005	3.1496	.0005	1.3750	.0047	.059	11,475	8,100	1.700	6,000	5,000
	35	.012	80	.011	34.925	.120	1.5	51,000	36,000	.771		
5308	1.5748	.0005	3.5433	.0006	1.4375	.0047	.059	12,712	9,225	2.200	6,000	5,000
	40	.012	90	.015	36.513	.120	1.5	56,500	41,000	.998		
5309	1.7717	.0005	3.937	.0006	1.5625	.0047	.059	15,412	11,475	3.120	6,000	5,000
	45	.012	100	.015	39.688	.120	1.5	68,500	51,000	1.415		
5310	1.9685	.0005	4.3309	.0006	1.7500	.0047	.079	18,337	13,837	4.250	5,000	4,000
	50	.012	110	.015	44.450	.120	2.0	81,500	61,500	1.928		
5311	2.1654	.0006	4.7244	.0006	1.9375	.0059	.079	21,375	16,425	5.110	5,000	4,000
	55	.015	120	.015	49.213	.150	2.0	95,000	73,000	2.318		
5312	2.3622	.0006	4.1181	.0007	2.1250	.0059	.079	28,100	22,162	7.000	4,000	3,000
	60	.015	130	.018	53.975	.150	2.0	125,000	98,500	3.175		
5313	2.5591	.0006	5.5118	.0007	2.3125	.0059	.079	31,950	25,425	8.500	4,000	3,000
	65	.015	140	.018	58.738	.150	2.0	142,000	113,000	3.856		
5314	2.7559	.0006	5.9066	.0007	2.5000	.0059	.079	35,775	28,800	1.500	3,800	2,800
	70	.015	150	.018	63.500	.150	2.0	159,000	128,000	4.763		
5315	2.9528	.0006	6.2992	.0010	2.6875	.0059	.079	37,800	31,500	11.000	3,600	2,600
	75	.015	160	.025	68.263	.150	2.0	168,149	140,125	4.990		
5316	3.1496	.0006	6.6929	.0010	2.6875	.0059	.079	45,200	53,100	14.500	3,500	2,400
	80	.015	170	.025	68.263	.150	2.0	201,068	236,210	6.577		

\*Maximum fillet which corner radius of bearing will clear.

